

Jøtul F 100 USA

Jøtul F 100 USA

Installation and Operating Instructions for use in USA and Canada	4
Exploded view	18



Keep these instructions for future reference.

USA/CANADA

Installation and Operation Instructions for USA/Canada Installation et fonctionnement pour Canada

Safety notice: If this solid fuel room heater is not properly installed, a house fire may result. For your safety, follow the installation directions. Contact local building or fire officials about restrictions and installation inspection requirements in your area. Save these instructions for future reference.

Avis de sécurité: Une installation non appropriée de ce poêle de chauffage risque de provoquer un incendie. Assurez votre sécurité en respectant les directives d'installation suivantes. Consultez les autorités locales du bâtiment ou de la prévention des incendies au sujet des restrictions et exigences relatives aux inspections d'installations dans votre région.

Tested and listed by ITS, Intertek Testing Services, Middleton, Wisconsin.
Tested to U.S. Standards: ANSI/UL 1482, Canadian Standards: CAN/ULC-S627-M93



Standards

The Jøtul F 100 USA woodstove has been tested and listed to:

U.S. ANSI/UL 1482

Canada: CAN/ULC-S627-M93

Tests performed by:

ITS, Intertek Testing Services, Middleton, WI

Manufactured by:

Jøtul AS, P.O. Box 1411, N-1602 Fredrikstad, Norway

Distributed by:

Jøtul North America Inc, 55 Hutcherson Drive,
Gorham, Maine 04038, USA

This heater meets the U.S. Environment Protection Agency's Emissions limits for wood heaters manufactured and sold after July 1, 1990.

Under specific test conditions, this heater has shown heat output at rates ranging from 7,700 to 27,000 BTU's per hour.

The Jøtul F 100 USA woodstove is *only* listed to burn wood. Do not burn any other fuels.

Read this entire manual before you install and use your new room heater.

Save these instructions and make them available to anyone using or servicing the stove.

Check Building Codes

When installing, operating and maintaining your Jøtul F 100 USA woodstove, follow the guidelines presented in these instructions, and make them available to anyone using or servicing the stove. Your city, town, county or province may require a building permit to install a solid fuel burning appliance.

In the U.S., the National Fire Protection Association's Code, NFPA 211, *Standards for Chimneys, Fireplaces, Vents and Solid Fuel Burning Appliances*, or similar regulations, may apply to the installation of a solid fuel burning appliance in your area.

In Canada, the guideline is established by the CSA Standard, CAN/CSA-B365-M93, *Installation Code for Solid-Fuel-Burning Appliances and Equipment*.

Always consult your local building inspector or authority having jurisdiction to determine what regulations apply in your area.

Accepted For Use
City of New York
Department of Buildings
MEA 368-04-E
Jøtul North America, Inc.



We suggest that our woodburning hearth products be installed and serviced by professionals who are certified in the U.S. by the National Fireplace Institute® (NFI) as NFI Woodburning Specialists or who are certified in Canada by Wood Energy Technical Training (WETT). 

Table of Contents

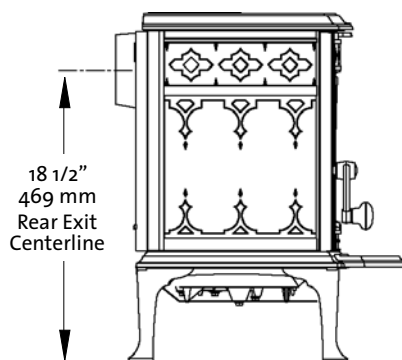
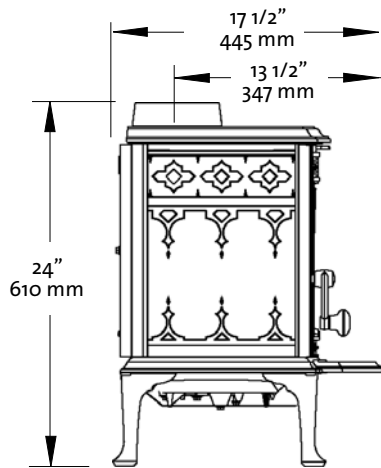
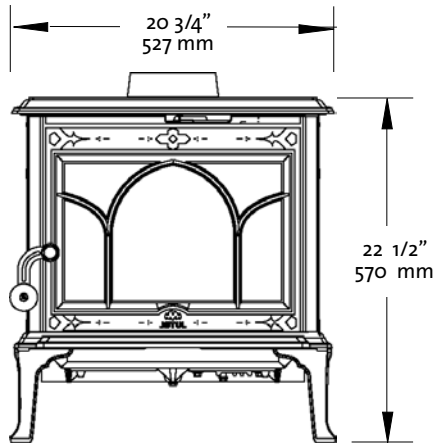

Standards and Safety Notices

Standards / Codes	2
Safety Notices	4

1.0 Installation

Flue Collar Installation	4
Chimney Connector	5

2.0 Chimney Requirements

Masonry Chimneys	6
Prefabricated Chimneys.....	6
Chimney Height.....	6
Wall Pass-Throughs.....	7

3.0 Connecting to the Chimney

Masonry Chimney	8
Hearthmount / Fireplaces.....	8
Prefabricated Chimneys.....	9

4.0 Clearances to Combustibles

Floor Protection	9
Clearances to Walls and Ceilings.....	10
Alcove Installation.....	10
Clearance Chart	12
Clearance Diagrams.....	13

5.0 Operation

Wood Fuel.....	14
Controls.....	14
Break-in Procedure	14
Starting / Maintaining the Fire.....	15
Formation of Creosote	15

6.0 Maintenance

Ash Removal	16
Glass Care.....	16

7.0 General Maintenance

Gaskets.....	17
--------------	----

8.0 Accessories

Stove-top Thermometer	17
Flue Collar Heat Shield.....	17

Illustrated Parts List.....	18-19
-----------------------------	-------

Safety Notices

- Burn solid wood fuel only
 - Do not use chemicals or fluids to start the fire. Do not burn garbage or flammable fluids.
 - If this room heater is not properly installed, a house fire may result. To reduce the risk of fire, follow the installation instructions. Failure to follow these instructions may result in property damage, bodily injury, or loss of life.
 - Contact the local building or fire officials about restrictions and installation inspection requirements in your area.
 - Do not connect this stove to any air distribution duct or system.
 - Extremely hot while in operation! Keep children, clothing and furniture away. Contact will cause skin burns.
 - *Install smoke detectors in the living areas and bedrooms of your home. Test them regularly and install new batteries twice annually. When installed in the same room as the stove, a smoke detector should be located as far from the stove as possible to prevent it from sounding when adding fuel to the fire.*
 - Avoid creating a low pressure condition in the room where the stove is operating. Be aware that operation of an exhaust fan or clothes dryer can create a low pressure area and consequently promote flow reversal through the stove and chimney system. The chimney and building, however, always work together as a system - provision of outside air, directly or indirectly to an atmospherically vented appliance will not guarantee proper chimney performance. Consult your local Jøtul authorized dealer regarding specific installation/performance issues.
 - Jøtul recommends that this stove be installed by a professional solid fuel technician or that you consult one if you do the work yourself. Also, consult your insurance company regarding any other specific requirements.
-

1.0 Installation

If this solid fuel room heater is not properly installed, a house fire may result. For your safety, follow the installation directions. Contact the local building or fire officials about restrictions and installation inspection requirements in your area.

Your local officials have final authority in determining if a proposed installation is acceptable. Any requirement by the local authority having jurisdiction that is not specifically addressed in this manual, defaults to NFPA 211, and local codes in the U.S. or in Canada, CAN/CSA-B365-M and local codes.

Assembly Before Installation

Unpack the Stove

Inspect the stove for damage. Contact your dealer immediately if any damage is found. Do not install the stove if any damage is evident.

Contents:

- Ash Lip
- Door Handle
- Hardware Bag
 - Flue Collar gasket
 - 6" Pipe Adaptor

Flue Collar Installation

The Flue Collar is oriented in the Top Exit position. Apply the gasket to the collar before installing the chimney connector.

Position Reversal

Follow this procedure to change the collar to a Rear Exit position if appropriate.

1. Remove the Flue Collar by reaching through the opening and removing the two bolts that secure it to the top plate.
2. Using tin snips, cut out the panel from the Rear Heat Shield for the Flue Collar to pass through. See **fig. 1**.
3. Remove the two screws that attach the Coverplate to the rear outlet. Hold onto the Coverplate while removing the second screw so that it does not fall out. See **fig. 2**.
4. Using the same screws, attach the Flue Collar to the rear outlet and the Coverplate to the Top Plate.
5. Install the Flue Collar gasket. Remove the protective paper from the adhesive side and apply the gasket to the inside of the Flue Collar.

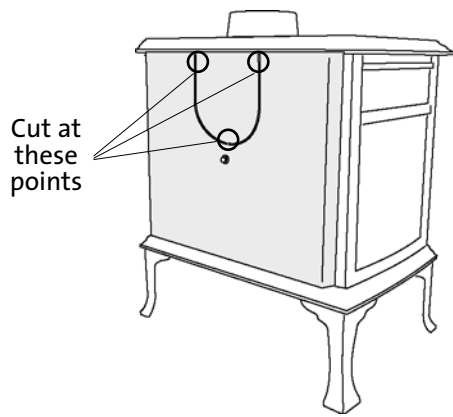

Figure 1. Rear flue collar cut-out.

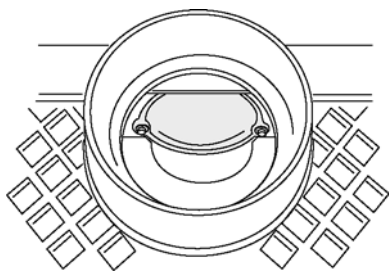

Figure 2. Remove the Rear Flue Outlet Coverplate.

Install the Ashlip

Attach the ashlip to the front by engaging the center tab with the slot located under the front door.

Assemble the Door Knob

Locate the white washer between the handle and the knob.

Chimney Connector

Use 6" single wall or listed 6" double-wall stovepipe to connect the stove to the chimney. Single wall stovepipe must be black iron or stainless steel and have a minimum thickness of 24 gauge. Do not use aluminum or galvanized steel pipe for chimney connection - these materials are not suitable for use with solid fuel.

Follow these guidelines regarding chimney connector construction:

- **Do not use chimney connector as a chimney. It is intended only for use as a connection device.**
- Each connector section must be oriented with the male (crimped) end pointing toward the stove. See **fig. 3.**
- Secure all connector joints with three sheet metal screws. The connection to the stove flue collar takes two sheet metal screws.

- For the best performance, the chimney connector should be as short and direct as possible, including no more than two 90° elbows.
- **The maximum vertical run of single wall stovepipe should not exceed 10 ft. (305 cm).**
- **The maximum horizontal run should not exceed 3 ft. (92 cm) with a 1/4" rise per foot.** Under no circumstance should horizontal pipe be allowed to slant down toward the chimney.
- No part of the chimney connector may pass through an attic or roof space, closet or other concealed space, or through a floor or ceiling. All sections of the chimney connectors must be accessible for cleaning. Where passage through a wall or partition of combustible construction is desired, the installation must conform with NFPA 211 or CAN/CSA-B365, and is also addressed in this manual.
- **Do not connect this stove to a chimney flue servicing another appliance.**

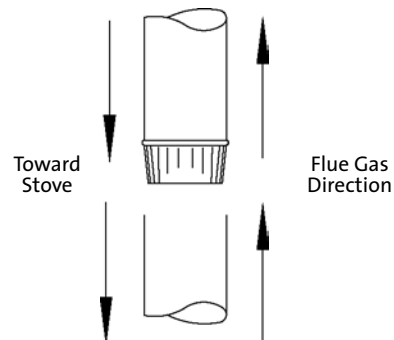

Figure 3. Chimney connector orientation.

2.0 Chimney Requirements

There are two types of chimneys suitable for the Jøtul F 100 USA :

1. A code-approved masonry chimney with a ceramic tile or listed steel flue liner.
2. A prefabricated chimney complying with the requirements for Type HT (2100°F) chimneys per UL 103 or ULC S629.

The chimney size should not be less than the cross-sectional area of the flue collar, and not more than three times greater than the cross-sectional area of the flue collar.

When selecting a chimney type and the location for the chimney in the house, keep this in mind: **It is the chimney that makes the stove work, not the stove that makes the chimney work.** This is because a chimney actually creates a suction, called “draft” which pulls air through the stove.

Several factors affect draft: chimney height, cross-sectional area (size), and temperature of the chimney, as well as the proximity of surrounding trees or buildings.

A short exterior masonry chimney will give the poorest performance because it will be difficult to warm the flue and sustain the temperatures necessary to maintain draft strength. In extremely cold climates, it may be necessary to reline the chimney or extend the height to help establish draft.

A tall, interior masonry chimney is easier to keep warm and will perform the best under a variety of weather and environmental conditions.

The following guidelines give the necessary chimney requirements based on the national code (ANSI-NFPA 211 for the US. And CSA CAN-B365 for Canada). However, many local codes differ from the national code to take into account climate, altitude, or other factors. Your local building inspector is the final approving authority. Consult them prior to installation.

Do not connect the stove to any air distribution duct or system.

Masonry Chimneys

When installing the Jøtul F 100 USA into a masonry chimney you must conform to all of the following guidelines:

- The masonry chimney must have a fireclay liner or equivalent, with a minimum thickness of 5/8” (14 mm) and must be installed with refractory mortar. There must be at least 1/2” (12.7 mm) air space between the flue liner and chimney wall.

- The fireclay flue liner must have a nominal size of 8” X 8” (20 cm x 20 cm), and should not be larger than 8”X 12” (20 cm x 30 cm). A round fireclay liner must have a minimum inside diameter of 6” (15 cm) and maximum inside diameter of 8” (20 cm). A larger chimney should be relined with an appropriate code approved liner.
- Brick or modular block must be a minimum of 4” (10 cm) nominal thickness. Stone construction must be at least 12” (30 cm) thick.
- A newly-built chimney must conform to local codes, or, in their absence, must comply with national regulations.
- An existing chimney must be inspected by a professional licensed chimney sweep, fire official, or code officer to ensure that the chimney is in proper working order.
- No other appliance may be vented into the same flue.
- An airtight clean-out door should be located at the base of the chimney.

Prefabricated Chimneys

A prefabricated metal chimney must be tested and listed for use with solid fuel burning appliances. High Temperature (HT) Chimney Standard UL 103 for the U.S. and High Temperature Standard ULC S-629 for Canada.

The manufacturer’s installation instructions must be followed precisely. Always maintain the proper clearance to combustibles as established by the pipe manufacturer. This clearance is usually a minimum of 2”, although it may vary by manufacturer or for certain chimney components.

Chimney Height

The chimney must be at least 3 feet (92 cm) higher than the highest point where it passes through the roof and at least 2 feet (61 cm) higher than the highest part of the roof or structure that is within 10 feet (3.05 m) of the chimney, measured horizontally. **See figure 4.**

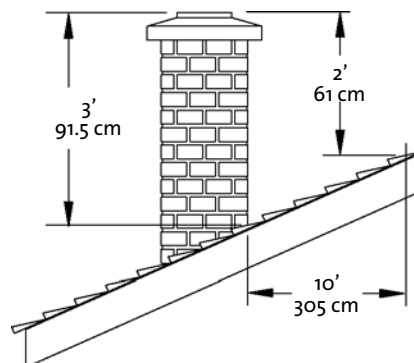

Figure 4. Chimney Height Requirement.

Chimneys shorter than 14 feet (4.27 m) may not provide adequate draft. Inadequate draft can result in smoke spillage when loading the stove, or when the door is open. Poor draft can also cause back puffing (ignition of gas build-up inside the firebox) and sluggish performance. The minimum height does not, in itself, guarantee proper chimney performance.

Excessive chimney height can promote over-strong draft resulting in high stove temperatures and short burn times. Excessive draft can be corrected by installing a butterfly damper. Your Jøtul dealer is an expert resource to consult regarding draft issues or other performance-related questions.

Wall Pass-Throughs

In the U.S.

The National Fire Protection Association's publication, NFPA 211, *Standard for Chimneys, Fireplaces, Vents and Solid Fuel Burning Appliances* permits four methods for passing through a combustible wall. Before proceeding with any method be sure to consult with your local building officials to discuss any local code requirements.

Common Method:

See **Figure 5**. Remove all combustible materials from the pass-through area (around the chimney connector), a minimum 12" (30.5 cm). A 6" (15.2 cm) diameter connector will require a 31" x 31" (78.7 x 78.7 cm) square opening.

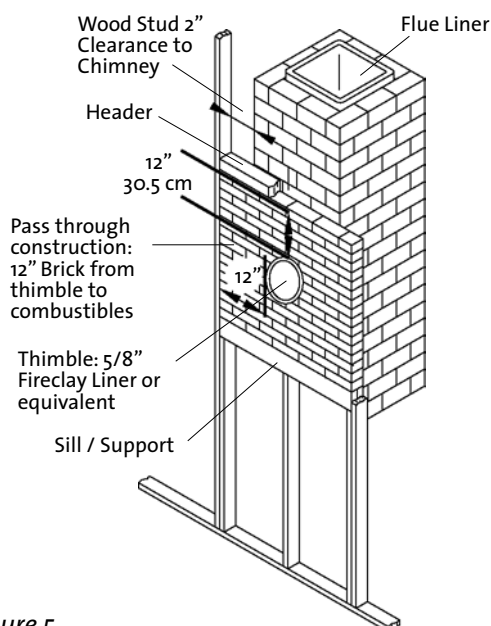

Figure 5.
Masonry Wall Pass-through.

The opening must be filled with at least 12" (30.5 cm) of brick around a fireclay liner. The liner must be ASTM C35 or equivalent, having a minimum wall thickness of 5/8" (16 mm).

The Pass-through must be at least 18" (45.7 cm) from combustible ceiling materials.

It will be necessary to cut wall studs, install headers, and construct a sill frame to maintain the proper dimensions and to support the weight of the brick.

The bricks must be solid brick with a minimum of 3 inches thick (nominal 4" / 102 mm).

Refractory mortar must be used at the junction of the chimney and the pass-through liner. The pass-through liner must not penetrate the chimney liner beyond the inner surface of the chimney liner. Use extreme care when constructing the hole in the chimney liner as the tiles can shatter easily.

In Canada

The installation must conform to CAN/CSA-B365, Installation Code for Solid Fuel Burning Appliances and Equipment. Before proceeding be sure to consult your local building inspector.

Common Method:

This method requires the removal of all combustible materials from at least 18" (45.7 cm) around the chimney connector's proposed location. A 6" round liner requires a minimum opening 43" x 43" (109.2 x 109.2) square.

Locate the pass-through at least 18" from combustible ceiling materials.

The space that is cleared of combustible materials must remain empty. Sheet metal panels can be used to cover the area. However, when using a panel on both sides of the wall, each cover must be installed on noncombustible spacers at least 1" from the wall. If one panel of sheet metal is to be used it may be installed flush to the wall.

See section 5.3.1 and 5.3.2 of CAN/CSA - B365-M91. Consult your local building inspector, authorized Jøtul Dealer, NFPA 211 in the U.S. or CAN/CSA-B635 in Canada for other approved wall pass-through methods.

USA/CANADA

3.0 Connecting to the Chimney

Masonry Chimney

When installing a Jøtul F 100 USA into a masonry chimney through a “thimble” (the opening through the chimney wall to the flue), the thimble must consist of ceramic tile or steel and be securely cemented in place.

The chimney connector/stove pipe must slide completely inside the thimble to the inner surface or the flue liner. It may be necessary to make use of a thimble sleeve (a pipe with a slightly smaller diameter than standard stove pipe). See figure 6.

The connector pipe or thimble sleeve must not protrude

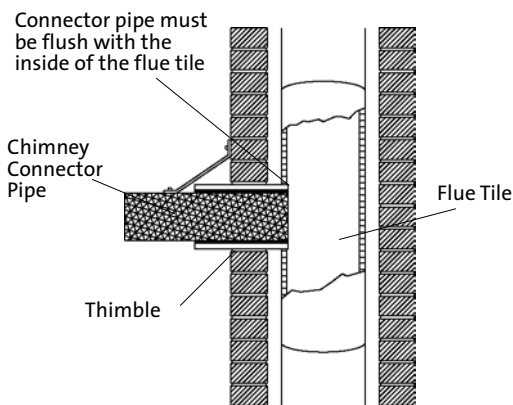

Figure 6. Masonry Chimney Thimble.

into the flue liner or otherwise restrict draft.

Use refractory cement to seal the seam between the chimney connector, sleeve, and thimble.

Do not connect this stove to a chimney flue servicing another appliance of any kind.

Hearthmount into a Masonry Fireplace

The Jøtul F 100 USA may be installed into a masonry fireplace with a minimum opening height of 22 1/2” (572 mm).

Building code requires that the fireplace damper plate be removed or securely fixed in the open position. A connector pipe must then extend from the stove’s flue exit through the damper area of the fireplace and into the chimney tile liner. See figure 7.

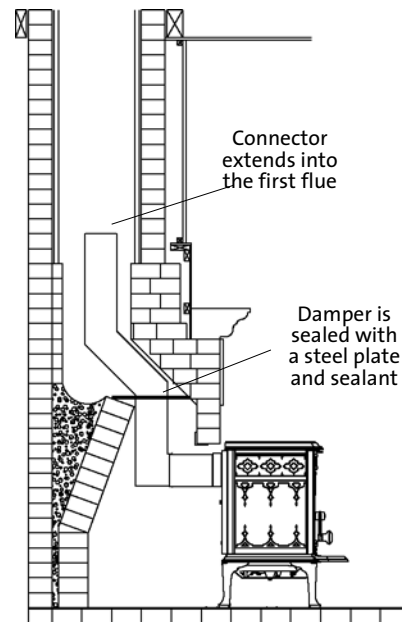

Figure 7. Hearthmount Installation.

The inside area of the flue liner must not be less than the area of the stove flue collar and cannot be more than three times greater than the cross sectional area of the stove flue collar.

If the chimney liner is too large to accommodate the stove, an approved relining system must be installed to resize the flue.

A new sheet metal damper block-off plate must be installed around the connector pipe at the damper frame and sealed with the proper sealant (usually High-Temp Silicone).

Prefabricated Chimneys

When connecting the Jøtul F 100 USA to a prefabricated metal chimney always follow the pipe manufacturer's instructions and be sure to use the components that are required. This usually includes a "smoke pipe adapter" that is secured to the bottom section of the metal chimney and allows the chimney pipe to be secured to it with two sheet metal screws. See figure 8.

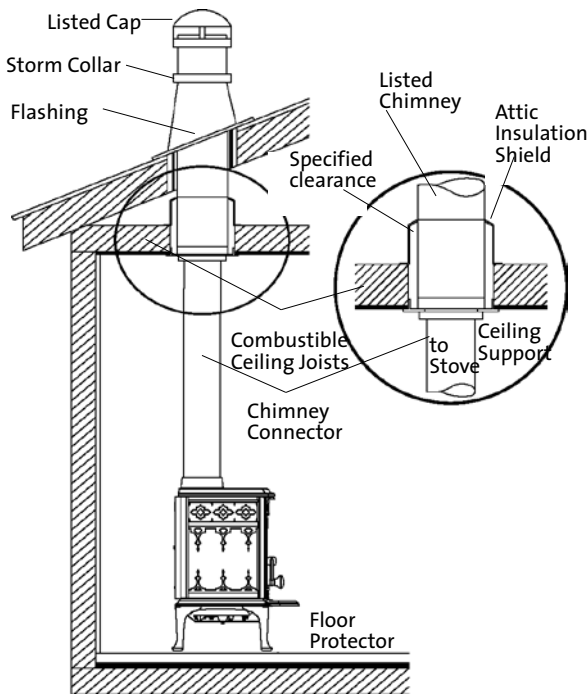

Figure 8. Prefabricated Listed Type HT Chimney.

4.0 Clearance to Combustibles

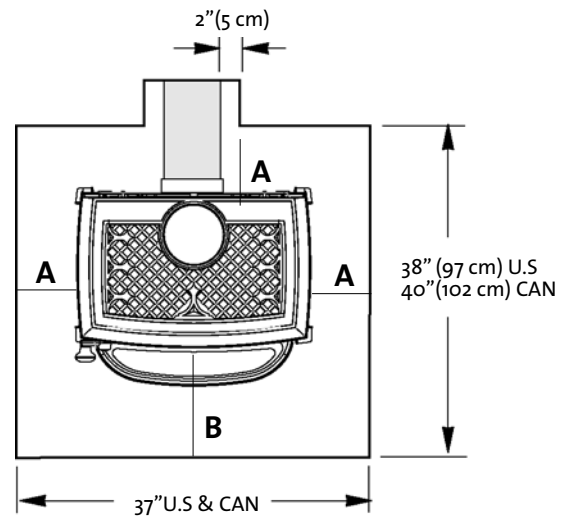

Figure 9. Hearth Protection.

- A: 8" (21 cm)
- B: 16" (US)
- B: 46 cm (Can)

Floor Protection

The Jøtul F 100 USA requires one of the following forms of hearth protection:

1. Any UL, ULC or WH listed hearth board. (No bottom heat shield required).
2. Any noncombustible material **with use of the bottom heat shield.**

All forms of protection must include a noncombustible surface extending forward from the glass panel at least 16" for the U.S., or 18" (46cm) for Canada. Protection must extend 8" (21 cm) from the sides and rear for both: the U.S. and Canada.

This will result in a minimum floor protection of 37" W x 38" D for the U.S. or 37" W x 40" D for Canada. See figure 9.

In a rear vent installation, the floor protection must also extend under the stove pipe a minimum of 2" (5 cm) beyond either side of the pipe. See figure 9.

Clearances to Walls and Ceilings

The clearances listed and diagramed in this manual have been tested to UL and ULC standards and are the minimum clearances to combustible materials specifically established for the Jøtul F 100 USA.

USA/CANADA

A combustible surface is anything that can burn (i.e. sheet rock, wall paper, wood, fabrics etc.). These surfaces are not limited to those that are visible and also include materials that are behind noncombustible materials.

If you are not sure of the combustible nature of a material, consult your local fire officials.

Remember: "Fire Resistant" materials are considered combustible; they are difficult to ignite, but will burn. Also "Fire-rated" sheet rock is also considered combustible.

Contact your local building officials about restrictions and installation requirements in your area.

See pages 12-13 for complete clearance requirements and diagrams.

Using Shields to Reduce Clearances

Chimney Connector Heat Shields: Use only connector heat shielding listed for use with solid fuel heaters. The connector heat shield must begin 1" above the lowest exposed point of the connector pipe and extend vertically a minimum of 25" (640 cm) above the top surface of the stove.

Double Wall Connector: Listed double wall pipe is an acceptable alternative to connector pipe heat shields. When using double wall connector, Flue Collar Heat Shield Kit 154996 must be installed on the stove.

Wall-Mounted Protection: When reducing clearances through the use of wall mounted protection:

In the U.S. refer to NFPA 211, Standard for Chimneys, Fireplaces, Vents and Solid Fuel Burning Appliances, for acceptable materials, proper sizing and construction guidelines.

In Canada, refer to CAN/CSA-B365, Installation Code for Solid-Fuel Burning Appliances and Equipment, also for acceptable materials, proper sizing and construction guidelines.

Notice: Many manufacturers have developed woodstove accessories that permit clearance reduction. Use only those accessories that have been tested by an independent laboratory and carry the laboratory's testing mark. Be sure to follow all of the manufacturer's instructions.

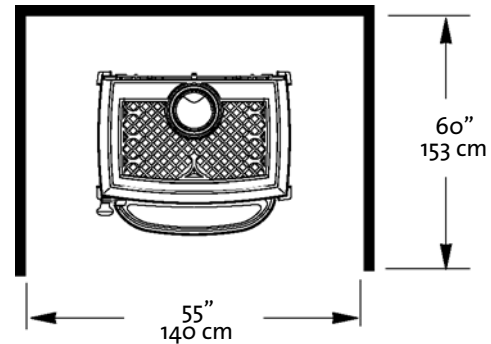

Figure 10. Alcove without Wall Protection.

Alcove Installation

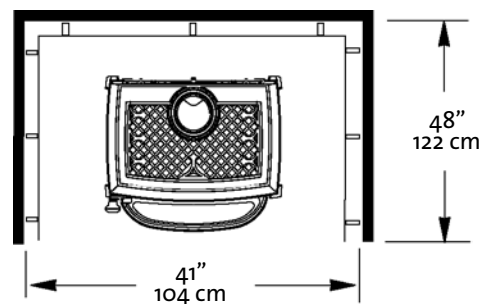

Figure 11. Alcove with Wall Protection.

The Jøtul F 100 USA can be installed in an Alcove as diagrammed in **figures 10 and 11**.

1. The stove must be installed with listed double wall pipe.
2. In a **protected** alcove installation both side walls and rear wall must be protected per NFPA 211 or CAN/CSA-B365. The wall protection must be elevated 1" (25 mm) from the floor and spaced at least 1" (25 mm) off the combustible wall, using noncombustible spacers, to allow for air circulation behind the shield.
3. The height of the wall protection including the bottom air space must be 48" (121 cm).
4. Alcove floor protection must consist of a UL/ULC or WHI listed hearth pad or a non combustible material with a minimum R value of 2.0.
5. Minimum ceiling height in an **unprotected** installation, off the top of the stove is 60" (153 cm). The minimum ceiling height off the top of the stove in a **protected** ceiling installation is 48" (122 cm).

Clearances to Fireplace Mantels and Surround Trim

See the Clearance Chart on **page 12** for approved clearances to combustible materials that may be part of fireplace construction. **See also fig. 12 on page 12**

USA/CANADA

Jøtul F 100 USA Clearance Chart

All clearances established with included stove rear heat shield installed.

Stove Clearances	Unprotected Surface Installation			Protected Surface per NFPA211 or CAN/CSA -B365-M93		
	Side A	Rear B	Corner* J	Side C	Rear D	Corner* K
Single-wall Connector	15" 381 mm	11" 280 mm	10" 254 mm	10" 254 mm	5" 127 mm	7" 178 mm
Single-wall Connector with Connector Shields or Double-wall Connector*	E 17" 432 mm	F 8" 203 mm	L 10" 254 mm	G 10" 254 mm	H 5" 127 mm	M 7" 178 mm
Chimney Connector Vertical Installation	Unprotected Surface			Protected Surface per NFPA211 or CAN/CSA-B365-M93		
Single-wall Connector	11" (280 mm)			6" (153 mm)		
Single-wall Connector with Connector Shields or Double-wall Connector*	8" (203 mm)			5" (127 mm)		
Chimney Connector Horizontal Installation	Unprotected Surface			Protected Surface per NFPA211 or CAN/CSA-B365-M93		
Single-wall Connector	18" (457 mm)			12" (305 mm)		
Double-wall Connector*	Manufacturer's Listing			Manufacturer's Listing		

* Double Wall Connector must be installed with Flue Collar Heat Shield Kit 154996.

Mantel and Trim Clearances

Top and Side Trim is 1" thick or less
Maximum Mantel depth 12"

Figure 12

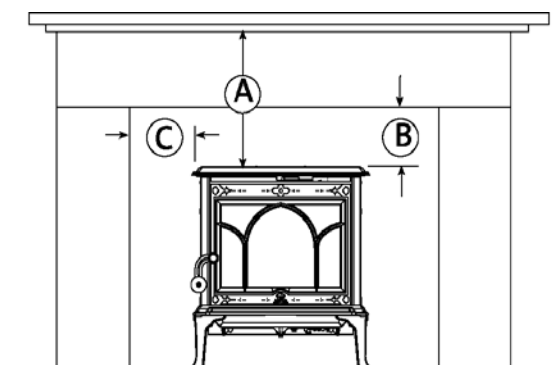

Unprotected Surfaces

A. Mantel 22" (560 mm)
B: Top Trim 17" (430 mm)
C: Side Trim 14" (355 mm)

Protected Surfaces

9" (230 mm)
8" (200 mm)
7" (430 mm)

Unprotected Surface
Parallel To The Wall

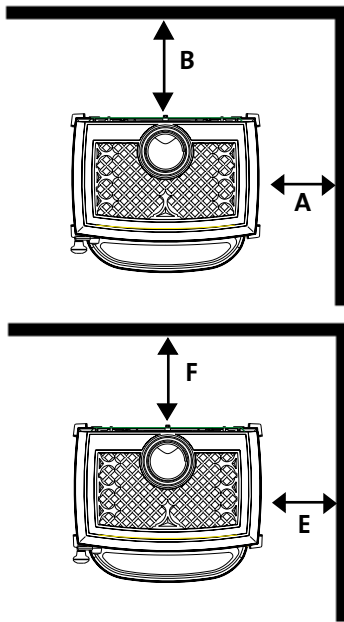

Protected Surface
Parallel To The Wall
PER NFPA 211 or
CAN/CSA-B365

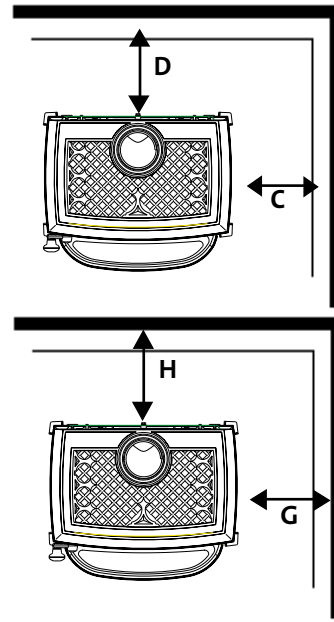

Important:
Connector heatshields and double wall pipe must be a listed product.
Always follow the manufacturer's instructions.

Unprotected Surface
Corner Installation

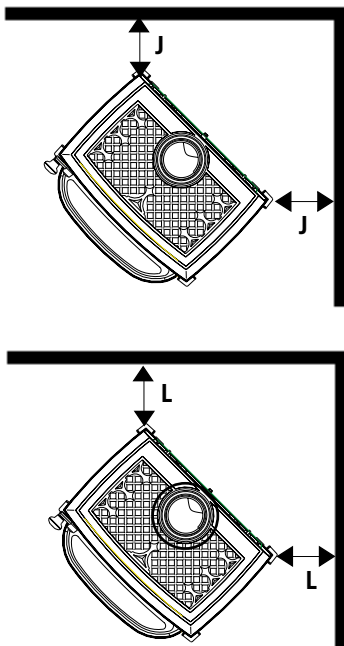

Protected Surface
Corner Installation
PER NFPA 211 or
CAN/CSA-B365

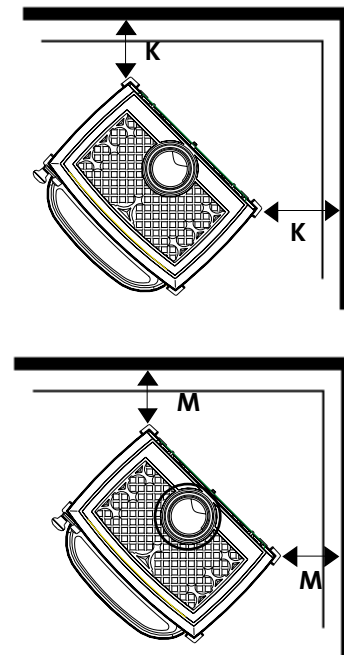

USA/CANADA

5.0 Operation

Please read the following section before building a fire in your new Jøtul F 100 USA.

Use Solid Wood Fuel Only

First this stove is designed to burn natural wood **only**. Wood that has been air-dried for a period of 6 to 14 months will provide the cleanest, most efficient heat.

Do not burn:

- Coal
- Garbage
- Cardboard
- Solvents
- Drift wood
- Treated or painted wood
- Chemical Chimney cleaners
- Colored paper
- Any synthetic fuel or logs
- Laminated wood

The burning of any of these materials can result in the release of toxic fumes. Never use gasoline, gasoline-type lantern fuel, kerosene, charcoal lighter fluid, or similar liquids to start or “freshen-up” the fire. Always keep such liquids away from the heater at all times.

Important: Never build or allow the fire to rest directly on the glass panels. The logs should always be spaced at least one inch from the glass to allow for proper air flow within the firebox.

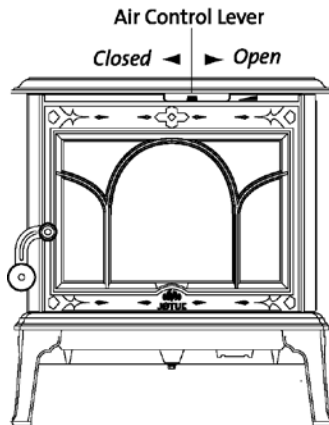

Figure 13. Slide the Air Control Lever to the right to increase combustion air and to the left to decrease combustion air.

Controls on the Jøtul F 100 USA

Combustion air is controlled by the **Primary Air Lever**, located above the Loading Door. The lever actuates a shutter over the air inlet which regulates the volume of primary air entering the firebox and controls heat output and burn time. See fig. 13.

When first starting or reviving the fire: the primary control lever should be at the far right position, which allows the maximum amount of air into the stove. The greater the amount of air entering the stove, the hotter and faster the fire will burn.

Moving the lever to the left reduces the airflow into the stove which prolongs the fire at a lower heat output.

Air Flow / Performance

Primary air enters the firebox directly above the glass panel on the door. The incoming air creates a turbulent barrier or “airwash” between the glass and the fire. Reducing the flow of primary air directly reduces the effectiveness of the airwash. Determining the primary air setting for the best overall performance for your particular needs and installation will best be established over time through trial and error.

Break-In Procedure

The Jøtul F 100 USA is constructed of cast iron and high temperature furnace cement. This type of construction requires the stove to be “broken-in” gradually so that heat expansion does not occur too quickly and cause damage. The following steps describe the proper break-in procedure for the Jøtul F 100 USA. Use a magnetic stove-top thermometer to monitor stove temperature, placed directly on the top plate.

- 1 Light a small fire of newspaper and kindling. Only allow the stove to reach a maximum surface temperature of 200°F (93°C). Burn for approximately 1 hour.
- 2 Allow the stove to cool to room temperature.
- 3 Light a second fire, allowing the stove to reach a maximum temperature of 300°F (149°C) for 1 hour.
- 4 Cool the stove to room temperature.
- 5 Light a third fire and gradually allow the stove to reach a surface temperature of 400°F (204°C)
- 6 Cool stove to room temperature. This completes the “break-in” procedure.

Note: If the temperature exceeds the limit during any break-in fire, move the primary air control lever all the way to the left to shut off the air supply completely. It is normal that the stove top temperature will continue to climb until the fuel burns down somewhat. Once the fire is out and the stove has cooled to room temperature, continue the break-in procedure. **Never attempt to reduce the temperature by removing burning logs from the fire.**

Breakin Odors: It is normal for a new painted stove to emit odor and smoke during the first few fires. This is caused by curing of the high temperature paint and will diminish with each fire. Open a window or door to provide additional ventilation to alleviate this condition.

Enamel Stove: You may notice moisture condensation on the surface of the stove during the first few fires. To avoid permanent spotting of the surface, use a soft towel to wipe the moisture away.

Starting and Maintaining a Fire

Burn only solid wood directly on the bottom grate of the stove. Do not elevate the fire in any way.

1. With the primary air control lever in the full open position (to the right), start with several sheets of crumpled newspaper placed directly on the grate. On top of the newspaper, place several pieces of small dry kindling (approx. 1" in diameter) with two to three larger logs (approx. 3" to 5" in diameter) on top.
2. Light the fire and close the door, slowly building the fire by adding larger and larger logs. Be sure to follow the break-in procedure before creating a hot fire that might damage the stove.
3. Once the stove has reached a surface temperature range of between 400° and 600°, (204°C -316°C), adjust the primary air control lever as necessary to generate the heat output and burn time desired. We recommend use of a magnetic stove top thermometer to monitor the surface temperature of the stove. The optimum surface temperature range for the most efficient burn is between 400° and 600° (204°C -316°C).

You can also monitor stove performance through the window. Peak combustion efficiency occurs when exhaust gas is burned at the baffle in the top of the firebox. This is apparent as yellow flames appearing at the secondary air ports in the underside of the baffle plate.

Never overfire the stove. If any part of the stove or chimney glows, you are overfiring. A house fire or serious damage to the stove or chimney could result. If this condition occurs, immediately close the air control.

Adding Fuel

When reloading the stove while it is still hot and a bed of hot embers still exist, follow this reloading procedure:

- Always wear gloves when tending to the stove.
- Push the air control lever to the full open position (far right).
- Wait a few seconds before opening the door.
- Use a stove tool or poker to distribute the hot embers equally around the firebox.
- Load the fuel, usually with smaller logs first.
- Close the door, be sure to latch the door tightly.
- Wait 5–10 minutes before adjusting the primary air to the desired heat output setting. (If you have at least a 2" thick ember bed when reloading, it may be possible to close the door and immediately adjust the air control setting).

Creosote and Soot Formation and the Need for Removal

When wood is burned slowly, it produces tar and other organic vapors which combine with expelled moisture to form creosote. These creosote vapors condense in the relatively cool chimney flue of a slow burning fire. The creosote that accumulates in the flue is highly flammable and is the fuel of chimney fires. To prevent a chimney fire, the creosote needs to be removed by sweeping the chimney and flue connector. The frequency of sweeping will depend on how you operate your stove, but it is important to inspect the flue after every two weeks of use. An accumulation of 1/4" or more on the sides of the flue or connector is considered hazardous and should be removed.

In the event that creosote in your chimney or flue connector ignites, the resulting fire is often accompanied by a roaring noise and a crackling sound as flakes of burned creosote break loose. If you suspect you are having a chimney fire, immediately close the draft regulator and make sure the stove door is closed. Call the fire department and get everyone safely out of the house.

Trying to extinguish the fire in the stove will not help. In fact it can make the matter worse by allowing oxygen through the door, which then supports the fire in the chimney. When the roaring and crackling has stopped, you should resist the temptation to open the door and look at the fire. The fire may have suffocated, but could rekindle when you open the door. After a chimney fire, do not use your stove until the chimney and the flue connector has been cleaned and inspected to ensure that no damage has been sustained.

6.0 Maintenance

Ash Removal

Ash removal will be required periodically, depending on how frequently the stove is used. Avoid letting the ash accumulate to spill over the Ash Fettle. For your protection, always wear safety gloves when handling the ashes. Use an ash shovel to remove the accumulation from the bottom of the firebox. The Fettle may be lifted from the front of the firebox to aid in ash removal.

Ashes should only be placed in a metal container equipped with a tight sealing lid. The container should be placed on a noncombustible floor or on the ground, well away from all combustible materials, pending final disposal. If the ashes are disposed of by burial in soil or otherwise locally dispersed, they should be kept in the closed container until all cinders have thoroughly cooled.

Glass Care

Cleaning

On occasion it will be necessary to clean the carbon deposits and fly ash off of the glass. If the carbon and fly ash are allowed to remain on the glass for an extended period of time it could eventually cause the glass to become etched and cloudy. Any creosote that might develop on the glass will burn off during the next hot fire.

Follow this cleaning procedure:

1. Glass needs to be completely cool.
2. Only use a cleaner that is specifically designed for this purpose. The use of abrasives will damage the glass and ultimately leave the glass frosted.
3. Rinse and dry glass completely before burning the stove.

Caution! Always operate the door slowly and carefully to avoid cracking or breaking the glass. Never use the door to push wood into the firebox. If the glass becomes cracked or broken follow the replacement procedure below.

Never operate the stove with a cracked or broken glass panel.

Important: Replace glass only with ceramic glass panel specifically designed for the Jøtul F100. Do not use substitutes. Replacement glass is available from your local Jøtul dealer.

Glass Removal or Replacement

The glass may be removed with the door in place.

1. Hold the glass in place while you remove the glass clips from the inside of the door. Lift the glass panel off of the two bottom tabs in the door.
2. Center the new glass panel over the gasket and reinstall the glass clips. **See figure 14.**
3. It may be necessary to retighten the glass clips after the stove has been burned and the gasketing has been seated.

Important: It is extremely important to tighten the glass clips gradually and alternately. Uneven or too great pressure can damage the glass.

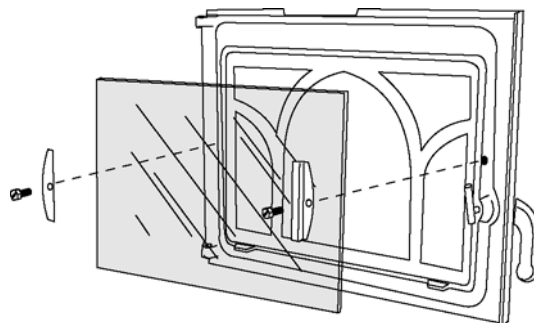

Figure 14. Glass and Gasket Replacement

Chimney System

The Jøtul F 100 is designed to burn cleanly and efficiently when used according to the guidelines in this manual. In order to maintain proper performance, you should inspect the chimney and chimney connector at the beginning of each heating season and then, twice a month during the heating season. Clean the chimney whenever creosote and fly ash accumulation exceeds 1/4 inch in any part of the system.

Chimney brushes are available from your local Jøtul dealer or hardware supply store. Your dealer can also refer you to a reputable, professional chimney sweep who will have all the equipment to ensure a complete and proper job. Failure to keep the chimney system free of creosote and build up could result in a serious chimney fire.

7.0 General Maintenance

As with your car, regular maintenance will prolong the life of your stove and ensure satisfactory performance.

- **Enamel Care:**
DO NOT ATTEMPT TO CLEAN HOT ENAMEL SURFACES. Clean only cold enamel surfaces with a soft damp cloth and polish with a clean dry cloth. DO NOT USE SOAPY OR ABRASIVE SOLUTIONS. These can cause stains. Coffee, tea, and fruit juices will also cause stains.
- Avoid contact with metal objects. Trivets, kettles, or pots, can damage the enamel.
- Empty stove of all soot and ashes. Only use a vacuum for this job if the vacuum is specifically designed for ashes.
- Inspect the stove seams. Use a utility light to inspect the stove inside and out for cracks or leaks. Replace all cracked parts and repair any cement leaks with furnace cement.

Gaskets

Check door and glass panel gaskets for tightness. To check the seal of the front door, close and latch the door on a dollar bill and slowly try to pull the dollar bill free. You should feel resistance as you pull. If it can be easily removed, the seal is too loose. Check several spots around the door.

Gasket Replacement

1. Use pliers and a putty knife to remove the old gasket from the door.
2. Thoroughly clean the channel with a wire brush.
3. Apply a small bead of cement to the channel.
4. Gently press the new gasket into the cement to seat it in the channel. Close and latch the door and then reopen. Wipe away any excess cement that may have squeezed out from around the gasket.

Gasket List for the Jøtul F 100 USA

Description	Part #	Size	Length
Top Plate Gasket	100038	3/8" LD	7
Flue Collar Gasket	200028	3/16" LD/SA	3'
Glass Gasket	100038	3/8" LD	5'
Door Gasket	100030	5/16" LD	5'

8.0 Accessories

Stove-Top Thermometer (# 5002)

Jøtul recommends the use of a magnetic stove-top thermometer to monitor the surface temperature of the stove.

The optimum surface temperature range for the most efficient performance is 400° F - 600° F (205° C - 316° C).

Flue Collar Heat Shield (# 154996)

This unobtrusive heat shield must be installed on stoves using double wall chimney connector to provide additional protection to combustible materials from heat radiating from the flue collar of the stove. The insulating properties of double wall pipe result in higher flue temperatures in this area than are generated in single wall connectors.

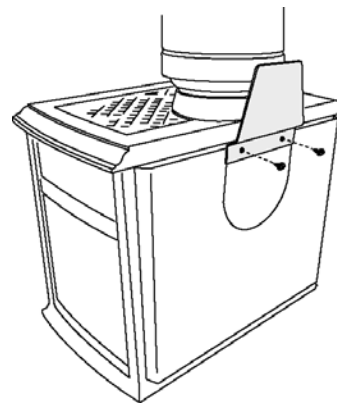

Figure 15. Attach flue collar heat shield.

Pos. no.	Description	Dim./Spec.
1	Side plate , left	Cast iron
2	Gasket (for rear plate)	LD 250-2 Ø6,4x750mm
3	Cover for air manifold	Cast iron
4	Heat shield rear	
5	Smoke outlet cover	Cast iron
6	Rear plate new	Cast iron
7	Gasket (for top)	LD 375-2 Ø9,5x1620mm
8	Baffle	Cast iron
9	Smoke outlet, non dripless Ø125	Cast iron
10	Gasket (for smoke outlet)	LD 187-1 Ø4,8x500mm
11	Top plate , complete	Cast iron
12	Inner bottom	Cast iron
13	Burn plate, side	Cast iron
14	Side plate , right	Cast iron
15	Valve	Cast iron BP
16	Valve plate	Cast iron
17	Gasket (for valve plate)	LD 250-2 Ø6,4x835mm
18	Air Deflector	Cast iron BP
19	Hinge pin	Ø6x33mm
20	Gasket (for door)	LD 375-2 Ø9,5x1620mm
22	Glass Clip	0,9mm steel
24	Gasket (for glass)	LD 250-2 Ø6,4x1300mm
25	Glass	379x270x4mm
26	Spring	4mm ceramic
27	Spring Pin	Ø5x24mm
28	Latch	Cast iron
29	Screw, machine pan head pozidrive	M6x40
30	Washer	Ø6,4xØ12,5x1,6, St8.8
31	Sleeve	Ø8xØ6xL27,5mm
32	Wooden knob	hard wood
33	Washer, insulating	Special
34	Nut hexagon	M6, St8.8
35	Washer, black-chromated, special	Ø10,5x25x1,5
36	Door , complete excl/glass	
37	Gasket (for door)	LD V-125 Flat 8x30mm
38	Latch bolt	st 37
39	Front plate	Cast iron
40	Ash lip packed	Cast iron
41	Log/Ash retainer	Cast iron BP
42	Leg 155mm	Cast iron
43	Valve/cover plate	Cast iron
44	Bottom plate	Cast iron
45	Heat shield, under	AluZn coated steel
46	Screw, hexagon cap	M6x50, St8.8
47	Screw, hexagon cap flange	M6x25, St8.8
48	Screw, hexagon cap flange	M6x16, St8.8
49	Screw, hexagon cap flange	M6x12, St8.8
50	Washer	Ø8,4xØ20x1,5, St8.8
51	Screw, machine pan head pozidrive	M6x8
52	Nut, cap flange	M6, St8.8
53	Gasket (for rear plate)	LD V-125 Flat 8x30mm
70	Sleeve	For Europe
71	Handle	For Europe
72	Loose handle	For Europe
72	Loose handle flat	For Europe
73	Ash pan	For Europe
74	Grate, (for multifuel)	For Europe
75	Inner bottom, rear, (for multifuel)	For Europe
76	Smoke outlet, dripless Ø125 new	Cast iron
76	Smoke outlet, dripless Ø125 UK	Cast iron

4_3854_P17

Cat.no 220223
Draw.no. 4-3954-P03
Jøtul AS - June 2008

Jøtul AS pursues a policy of constant product development. Products may therefore differ in specification, colour and type of accessories from those illustrated and described in this manual.

Quality

Jøtul AS utilizes quality controls conforming to NS-EN ISO 9001 for product development, manufacturing, and distribution of stoves and fireplaces. This policy is intended to provide you with the peace of mind that the Jøtul product you purchase meets or exceeds current uniform standards for quality and safety - a continuation of the standards instituted at the company's inception in 1853.

We appreciate your trust in welcoming our product into your home and invite your comment and appraisal of our efforts to provide you with the finest in home hearth products.

Jøtul North America Inc.

55 Hutcherson Drive
Gorham, Maine 04038
USA

Jøtul AS

P.o. box 1411
N-1602 Fredrikstad,
Norway

This product has been controlled by:

_____ Date:

_____ Sign:

